



Tempus



TEMPUS IRIS Project Quality Assurance

Uwe Brandenburg | Project Kick-Off Meeting | February 2013



Project number 530315-TEMPUS-1-2012-1-IL-TEMPUS-JPGR

This project has been funded with support from the European Commission.

This publication [communication] reflects the views only of the author, and the Commission cannot be held responsible for any use which may be made of the information contained therein.

Tools used...

Quality policy:

- To emphasize the four main principles (efficiency, effectiveness, punctuality, partner involvement)
- To clarify the roles: lead and normal partner



Four core aspects of successful work

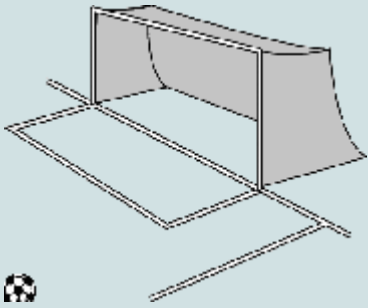

Efficiency:
Goal-oriented work



Effectiveness:
Useful results



Punctuality:
Respect the deadlines!



Partner involvement:
Work together



As a lead partner...

You are responsible for the completion of your work package!

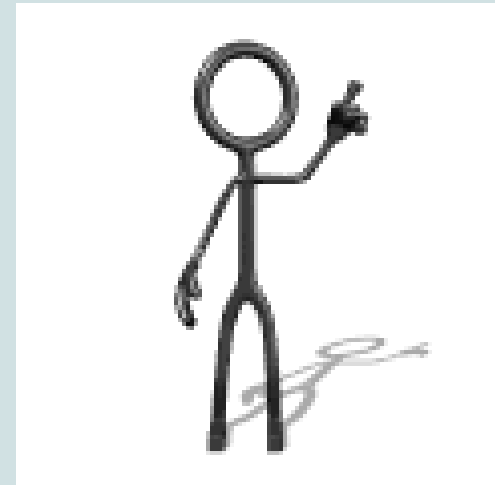

As a lead partner...

1. Plan ahead! Make a list of your activities and their timing!



As a lead partner...

2. Involve your partners! Be aware what everybody has to do!

Communicate regularly!

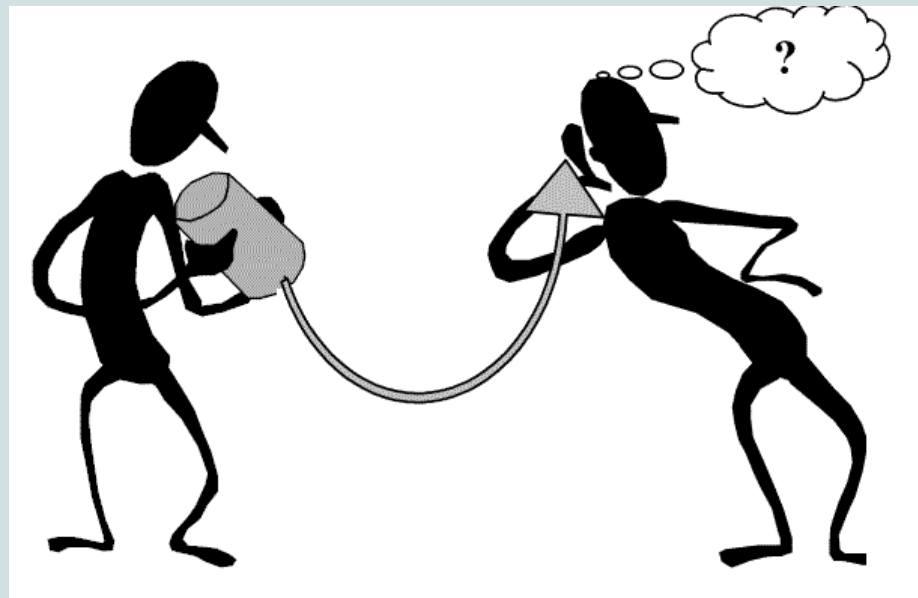

As a lead partner...

3. Keep in mind: your work must be helpful to entire project



As a lead partner...

4. Payments will only be made if HIT is satisfied with results



As a lead partner...

5. Communicate changes with HIT and CHE Consult.



As a partner...

You are part of a **team, so :**

- Support your coordinator
- Do it right the first time
- contribute quality and keep the final goals in mind
- Be pro-active, don't wait for the lead partner to ask you to do things
- If you see a problem communicate



Tools used...

Quality plan per work package:

- To help lead partner to follow through with a WP
- To assist SC and coordinator in monitoring individual progress



Tools used...



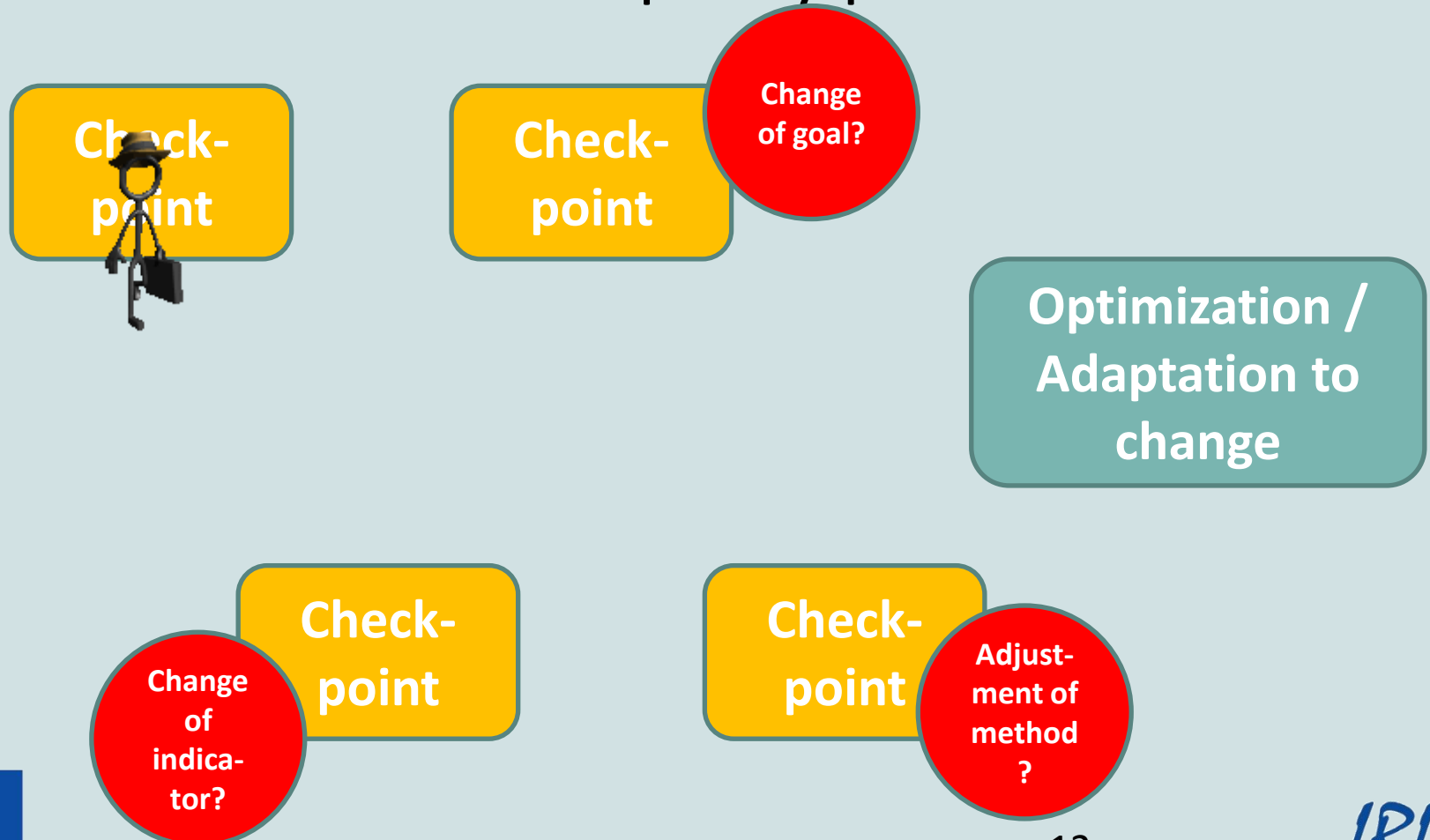

How to work with the quality plan:



Tools used...

Survey on progress & delivery monitor:

- Online survey with minimal time investment
- All partners are asked to respond
- To visualise the entire project progress

No.	Title of deliverable	Responsible partner	Date	Rating of the four basic criteria			
				Effectiveness	Efficiency	Punctuality	Partner involvement
1.1	Development and performance of requirements analysis survey	P1	5/13	5.1 	3.9 	2.8 	4.8 



How will quality assurance work?

Quality Policy Document:
Agreement how to work together

Survey on project progress and management:
Is everybody happy?

Measure indicators of progress:
Are we on track?



Tools used...

Evaluation forms:

- To control the quality of the different meetings and activities
- To monitor progress (or not)
- To help to improve the effectiveness and efficiency of the activities



Thank you for your attention
and
good success to our project!

